

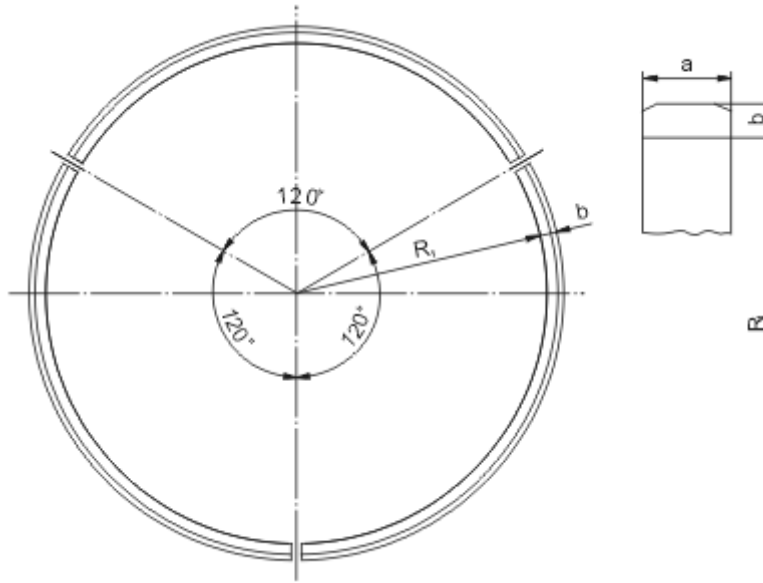

Type U Split Ring



Unit : mm

DN	Dimension			A Set of Weight (kg)
	$R_1$	a	b	
700	368.5	55	21	19.0
800	420.0	55	21	21.6
900	471.5	55	21	25.8
1000	522.5	60	21	29.3
1100	574.0	60	21	32.1
1200	625.0	60	21	34.9
1350	702.0	70	21	45.9
1500	779.0	75	21	54.6
1600	827.0	55	25	50.5
1650	852.5	55	25	52.0
1800	926.0	55	25	56.4
2000	1032.5	60	25	68.7

Tolerance Unit : mm

DN	Tolerance		
	$R_1$	a	b
700 2000	+1.0 -2.5	±1.5	0 -3.0